

EXAM II

Read each question carefully and choose the **ONE BEST ANSWER**. Two points each.

1. The **main** explanation for the lack of a continuing abiotic origin of life on Earth today is that
 - a. there are no molten surfaces on which weak solutions of organic molecules could polymerize.
 - b. all habitable places on earth are already filled to capacity.
 - c. there is much less visible light reaching Earth now than when life first originated.
 - d. there is not enough lightning to provide an energy source.
 - e. our oxidizing atmosphere is not conducive to spontaneous formation of complex molecules.
2. Imagine a sea filled with early protobionts of many different types, all competing for space and resources. Such competition would lead to natural selection between protobionts only when
 - a. photosynthesis first evolved.
 - b. they were first able to enzymatically catalyze reactions.
 - c. some kind of hereditary mechanism developed.
 - d. they were able to increase in size and divide in two
 - e. DNA first appeared.
3. Which of the following paired events represents a probable order in Earth's biological history?

a. metabolism before mitosis	d. DNA genes before RNA genes
b. eukaryotes before prokaryotes	e. animals before algae
c. oxidizing atmosphere followed by reducing atmosphere	
4. Current debates about (1) how many kingdoms there are, and (2) which organisms belong in each kingdom focus **mainly** on which of the following groups of organisms?

a. fungi and animals	d. plants and animals
b. prokaryotes and protists	e. birds and reptiles
c. plants and fungi	
5. The early Silurian period saw the first colonization of terrestrial environments by multicellular organisms. These were primarily

a. vertebrates	d. amphibians and reptiles
b. flowering plants and fungi	e. early land plants and arthropods
c. small, wormlike organisms	
6. The first step towards the generation of our earth's oxygen-rich atmosphere was the evolution of

a. aerobic metabolism in prokaryotes	d. colonization of land by plants
b. chlorophyll a	e. the ozone layer
c. eukaryotic green algae	
7. The two taxonomic domains of prokaryotes are

a. Protista and Bacteria	c. Archaea and Bacteria	e. Bacteria and Fungi
b. Protista and Fungi	d. Archaea and Eukarya	
8. The uptake and incorporation of DNA from the environment (transformation) by ancient prokaryotes may have resulted in _____ between taxonomic lineages.

a. endosymbiosis	c. autogeny	e. none of the above
b. lateral gene transfer	d. conjugation	

9. Certain types of bacteria use solar energy to help them harvest the energy in reduced organic compounds produced by other living organisms. Metabolically, these bacteria are known as
- chemoheterotrophs
 - photoheterotrophs
 - photoautotrophs
 - detritivores
 - decomposers
10. Gram staining is a means by which investigators can
- determine antibiotic sensitivity in bacteria
 - determine the level of pathogenicity of bacteria
 - identify bacteria on the basis of cell wall characteristics
 - sequence bacterial DNA
 - all of the above

Use the cladogram of Caminalcules below to answer #11 - 15

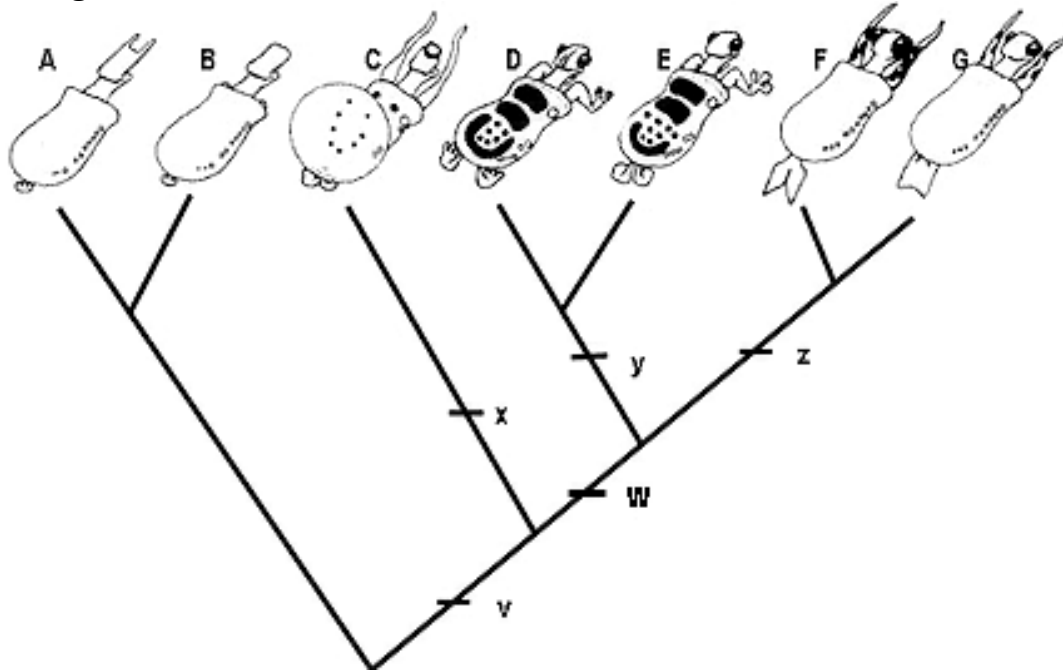

11. If the species shown above were to be classified into the following genera:
- Genus 1: Species A
 Genus 2: Species B, C, D, and E
 Genus 3: Species F and G
- which of the genera--if any--would be polyphyletic?
- Genus 1
 - Genus 2
 - Genus 3
 - more than one of the above
 - insufficient information shown to determine
12. Which of the following is most likely to be the character marked "x" on the cladogram?
- presence of two eyes
 - bulbous posterior
 - rear appendages
 - finlike tail
 - spots on body
13. Which of the following traits is a symplesiomorphy with respect to Genus 3, but a synapomorphy with respect to all the other species on the tree?
- presence of eye spots
 - presence of a head
 - small, lateral spots on body
 - finlike posterior appendage
 - two eyes
14. Judging only from the information you see on the cladogram, you can confidently say that Species C is more closely related to [Species D and E] than it is to [Species F and G].
- true
 - false
 - how should I know?!

15. If character "w" is "presence of two separate eyes," then the most parsimonious explanation for presence of two separate eyes in both the [Species D and E] clade and the [Species F and G] clade is _____ with respect to *only* those four species.
- a result of convergent evolution
 - homologous
 - analogous
 - a selective advantage
 - a synapomorphy
16. What is most functionally distinctive about the various types of chlorophylls found in photosynthetic bacteria and other photoautotrophs?
- their membrane structure
 - their roles in carbon fixation
 - their absorption spectra
 - their location in the cell membrane
 - their rate of radioactive decay
17. Why, after the first photoautotrophs started producing oxygen as a byproduct of photosynthesis, did it take about 1.2 billion more years for O₂ to begin to enter the atmosphere?
- Autotrophs produced only enough oxygen for themselves to use in respiration
 - Heterotrophic bacteria were using oxygen as quickly as it was produced
 - The first autotrophs produced ozone, which took that long to decay into oxygen.
 - Exposed iron in the earth's crust took 1.2 billion years to become fully oxidized.
 - Oxygen was absorbed by water, which never transfers gases to the atmosphere
18. The abnormal increase in temperature now being experienced by Planet Earth due to human activity (e.g., burning fossil fuels) is known as
- Global Warming
 - The Greenhouse Effect
 - Loss of Ozone Layer
 - Artificial Selection
 - more than one of the above
19. A detritivore
- breaks down organic matter into its inorganic components
 - breaks down organic matter into smaller units of organic matter
 - can construct organic molecules out of inorganic ones
 - can fix nitrogen by using the energy in organic molecules
 - is a munchy, crunchy snack
20. *Giardia* is of interest to evolutionary biologists mainly because
- it contains extremely primitive chloroplasts
 - its organelles are similar to prokaryotic organelles
 - it has a complex cytoskeleton composed entirely of flagellin
 - it exhibits primitive characters reminiscent of an early endosymbiotic eukaryote
 - it is pathogenic
21. The image diagrammed at the right is a cross section through an anatomical structure found in certain living organisms. Its characteristic "nine surrounding two" appearance should tell you immediately that this is a
- monocot root
 - pine leaf (needle)
 - bacterial flagellum
 - root trichome
 - eukaryotic flagellum



23. Diatoms, giant kelps and water "molds" all belong to candidate kingdom Stramenopila. Which of the following synapomorphies sets them apart from all other protists?
- a system of alveoli under the plasma membrane
 - chlorophyll c
 - a very primitive form of cilia
 - photoautotrophy
 - phycocyanin and phycoerythrin pigments
24. Which of the following sets of shared characteristics most likely represents the result of **convergent evolution**, rather than common ancestry? (Note: all the characteristics shown actually are shared by the organisms listed. No tricks.)
- flagella and cilia in various groups of protists
 - the pigment fucoxanthin in diatoms and kelps
 - solid test (shell) surrounding the protoplast in diatoms, dinoflagellates and foraminiferans
 - an alveolar system under the plasma membrane in ciliates and dinoflagellates
 - similar cell plate formation in green algae (Chlorophyta) and plants
25. Mitochondrial and chloroplast genomes are circular, much like bacterial chromosomes.
- true
 - false
 - I'd rather be skydiving
26. True multicellularity is partly defined by the presence of distinctive cell types, often exhibiting division of labor. At the cellular level, what does this diversification imply?
- The organism must be able to reproduce sexually
 - The individual cells of the organism must be very large
 - The individual cells of the organism must be able to move freely
 - Cells of different types have different genomes
 - Cells of different types express different genes
27. The term "protist" is a descriptive (i.e., not taxonomic) term that can be applied to all eukaryotes *except*
- extinct ones
 - those consisting of more than one cell
 - land plants, animals, and fungi
 - those with a membrane-bound nucleus
 - those having chlorophyll a and b
28. Which of the following types of symbiotic associations is never seen in fungi?
- mutualism
 - parasitism
 - parasitoidism
 - predation
 - various fungi may be symbionts in any of the associations listed above
29. Not including the specialized cells located along their gills, the clumped hyphae of the mushrooms you had on your last pizza were
- haploid
 - ascocarps
 - basidiospores
 - dikaryotic
 - diploid
30. The Form Phylum "Deuteromycota"
- consists only of fungi that have secondarily lost the ability to reproduce sexually
 - is probably comprised primarily of asexual ascomycetes
 - includes several commercially important species
 - is made up of fungi that reproduce only asexually, via conidia
 - all of the above
31. Common antibiotics used to treat bacterial infections are usually effective against fungal infections, as well.
- true
 - false
 - I hope I never personally find out

The diagram below shows a longitudinal section of two types of mycorrhizal associations, Vesicular Arbuscular (V.A.M.) on the left, and ectomycorrhizae on the right. Use the information to answer #32 - 35.

32. The owner of the root on the right side of the diagram is most likely to be
- | | |
|-----------------|---------------------|
| a. a corn plant | d. black bread mold |
| b. an epiphyte | e. Farmer Bob |
| c. an oak tree | |

33. Which of the structures in the diagram function as a nutrient bridge between the plant and its fungal partner?
- | | | |
|------------|------------|----------------------|
| a. e and d | c. c only | e. none of the above |
| b. f and a | d. a and b | |

34. The structure marked "g" actually extends much farther from the root than shown in the diagram. In reality, it may stretch many meters away from the plant's farthest root tip. The function of "g" is to
- destroy pathogens before they reach the plant
 - provide the plant with sugars and amino acids
 - increase the absorptive surface area of the roots
 - extend the plant's photosynthetic area
 - more than one of the above

35. The structure marked "b" is a single-cell layer that acts as a selectively permeable membrane between the root stele and outer tissues. Which of the following is TRUE?
- mycorrhizal hyphae normally penetrate this layer without harming the plant
 - layer "b" is known as the endodermis
 - layer "b" is meristematic
 - mycorrhizal hyphae may pass *around* the cells of this layer, but not through their membranes
 - more than one of the above is true

36. The orange you left sitting on your desk gradually got flatter and soggy, and soon was covered by a beautiful, bluish mantle of *Penicillium* fungus. Looking at it under the microscope, you noticed that the hyphae were tipped by handsome structures that looked a bit like tiny paintbrushes, and that the "hairs" of the brushes were composed of small, round units that easily broke off and went their merry way. The brushlike structures
- | | |
|---|--|
| a. are involved in asexual reproduction | d. manufacture the fungus' chemical defenses |
| b. are mycorrhizae | e. secrete digestive enzymes into the orange |
| c. produce spores via meiosis | |

37. An epiphyte is
- | | |
|--|----------------------|
| a. a aerial vine that grows in tropical rainforest | d. a parasitic plant |
| b. a specialized root that allows one plant to parasitize another | e. a fungal symbiont |
| c. a plant that grows on the surface of another plant, but does not obtain nutrients from it | |

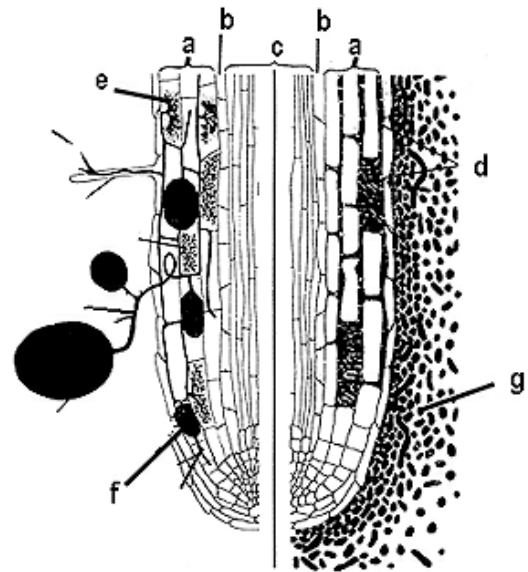

38. In plants, the appearance of the waxy cuticle and stomata are correlated with which of the following major evolutionary events?
- evolution of the first erect growth forms
 - colonization of land
 - evolution of aerobic metabolism
 - evolution of woody tissues
 - evolution of vascular tissues
39. Which of the following is true of secondary growth?
- It results from mitosis in the cork cambium
 - It increases the height of the plant
 - It results from mitosis in the apical meristems
 - It produces phloem towards the inside of the stem and xylem towards the outside
 - It results in an increase in a woody plant's girth/diameter
40. A sieve tube element is
- nucleated and alive at maturity
 - a derived type of water-collecting cell
 - the hairlike extension on a trichome
 - a nutrient-conducting component of phloem
 - dead and hollow at maturity
41. The three primary meristems are
- vascular, ground, and dermal
 - parenchyma, collenchyma, and sclerenchyma
 - protoderm, ground meristem, and procambium
 - apical, axillary and cambial
 - stele, cortex, and epidermis
42. At the start of the growing season, when water is plentiful, xylem elements with relatively large lumens are produced by the vascular cambium. Later in the season, when growth slows, the elements have narrower lumens, and the wood is somewhat denser. This describes
- heartwood and sapwood
 - softwood and hardwood
 - springwood and summerwood
 - xylem and phloem
 - deadwood and driftwood
43. Which of the following is NOT TRUE of the charophytes, sometimes referred to as an evolutionary "link" between the green algae and land plants?
- they have parenchyma-like cells
 - cell plate formation and other mitotic events are nearly identical to those in plants
 - the zygote develops inside the female reproductive organ (archegonium)
 - like plants, they undergo a heteromorphic alternation of generations
 - a lignin-like compound is present in charophyte cells
44. Which of the following characters are shared by all bryophytes, but not by any tracheophytes?
- primitive xylem and phloem elements
 - highly developed waxy cuticle to compensate for stomates that cannot open and close
 - Isomorphic alternation of generations
 - internal fertilization and early growth of the zygote into the sporophyte
 - The obvious, long-lived generation is the haploid gametophyte.
45. Which of the following is NOT TRUE of indeterminate growth in plants?
- It results from growth of pluripotent cells present throughout the life of the plant
 - It results in a plant's growth being especially responsive to environmental conditions
 - It makes it possible for somatic mutations to be passed to future generations
 - It occurs only during a predetermined juvenile period
 - All of the above are TRUE of indeterminate growth.

46. Lignin

- a. confers compressional strength to plant tissues
- b. is found mostly in herbaceous plants
- c. is the main structural component of parenchyma
- d. is a large, inorganic compound
- e. is produced only in the roots

Use the diagram below to answer #47 - 49. HINT: The layers labeled "C" and "E" are meristematic.

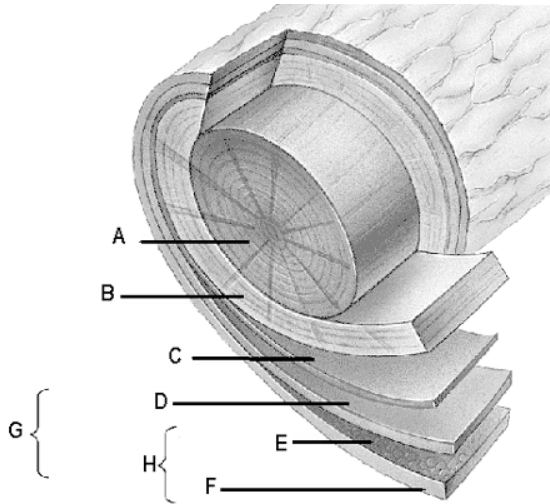

47. The layer(s) responsible for *permanent* second growth in this tree is/are

- a. A
- b. B
- c. C
- d. E
- e. more than one of the above

48. Which of the following layers are composed of dead and/or hollow cells at maturity?

- a. A and B
- b. C and D
- c. D and E
- d. E and F
- e. A, B and F

49. Which of the layers in this diagram would split & be fully replaced by new growth if this tree were allowed to grow for about 30 more years?

- a. A and B only
- b. C and D only
- c. E, and F only
- d. C, D, E, and F
- e. all the layers would be completely replaced

50. Which of the following parts of a leaf are cellular, but contain no chloroplasts?

- a. cuticle
- b. epidermis
- c. palisade mesophyll
- d. spongy mesophyll
- e. more than one of the above